

SGP 2300 / 4300 Fully Automatic Strapping Machine



Standard Equipment

- Adjustable working height
- Four castors, two with brakes
- Closed strap arch system
- Heat seal
- Automatic strap threading device
- Automatic strap and ejection
- Foot pedal
- Control panel with digital display
- Strap loop ejection for cycles without product
- Cycle counter
- Electrical supply cable, 5m / 5.5 yd.
- Dispenser position: side mounted
- Error message display
- Strap tension key «Soft»



Sigma Supply of North America, Inc.
824 Mid America Boulevard, Hot Springs, AR 71913

Phone: 501-760-1511
Fax: 501-760-1521
www.sigmasupply.com
equipment@sigmasupply.com

SGP 2300 / 4300

Technical Data / Layout

Technical Data

Heat weld sealing	
Preheating time	30 s
Electrical supply	Single phase AC 230 V / 50 Hz, 1PH and 115 V / 60 Hz, 1PH Tolerance -15%/+20% Main fuse 10 A

Performance at 225VAC	Mode Sleep	Mode Stand-by	Mode Oper.Max
Watt	26 W	63 W	607 W
Volt Amp	38 VA	64 VA	622 VA
Reactive Power	27 VAR	9 VAR	193 VAR
Power Factor	PF 0.60	PF 0.88	PF 0.98
COS Phi	0.69	0.99	0.99
Amp	0.19 A	0.32 A	3.0 A

Arch Dimension

Machines	Strap Width	Arch Dimension (WxH)	Strap Tension
SGP 2300	5 mm (1/4")	650 x 500 mm (26 x 20")	300 N
		850 x 650 mm (33 x 26")	300 N
		850 x 850 mm (33 x 33")	300 N

Machines	Strap Width	Arch Dimension (WxH)	Strap Tension
SGP 4300	9 / 12 mm (3/8 / 1/2")	650 x 500 mm (26 x 20")	450 N
		850 x 650 mm (33 x 26")	450 N
		850 x 850 mm (33 x 33")	450 N
		850 x 1250 mm (33 x 49")	450 N
		1250 x 500 mm (49 x 20")	450 N
		1250 x 850 mm (49 x 33")	450 N

Room temperature	10 - 40°C	(50 - 104°F)
Relative humidity	10 - 65%	
Cycles per minute up to*	70/min.	
(without conveyor)		
Working heights	see layout	
Machine weight	170 kg	(375 lbs)
Color	Black RAL 9005, slate grey RAL 7015	
IP- Protection level	without IP protection	

Packages

Width x height min.	100 x 20 mm	(4 x 0.8")
Width / height max.,	. / 50 mm	(. / 2")
Arch dimension		
Length min.	--	--
Weight max.	35 kg	(77 lbs)

Plastic Strap (PP)

Strap width	5 mm	(1/4")
	9 mm	(3/8")
	12 mm	(1/2")
Strap thickness	0.40 - 0.60 mm	(0.015 - 0.024")
Strap coil, Ø inside/outside	200 / 430 mm	(8" / 17")
Strap tension 5 mm (1/4")	300 N	
9 - 12 mm (3/8 / 1/2")	450 N	

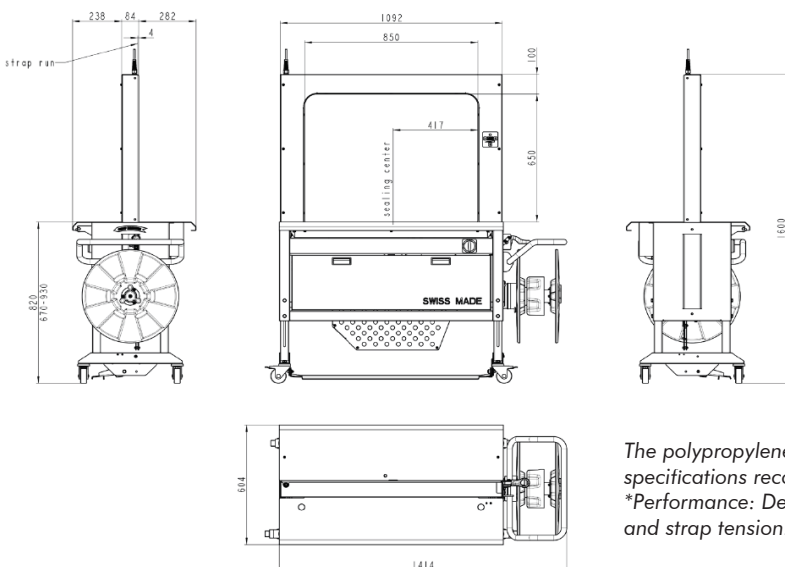

The polypropylene straps used for the respective applications must correspond with the strap specifications recommended by Signode!

*Performance: Depends on arch and package dimensions, conveyor speed, package distances and strap tension.